

Product Manual

of

Infrared Forehead Thermometer

Product number: QY-EWQ-01

Thank you for purchasing our infrared forehead thermometer.

Please read the manual before using.

After reading, please keep it in a safe place for future reference.

Registrant/production company/after-sales service unit: Hangzhou Qingyuan Medical Equipment
Technology

Address/production address: No. 688 Dongan 1st Road, Xintang Street, Xiaoshan District, Hangzhou,
Zhejiang Province

Tel: 0571-82623931

Document number: QY-WI-ADE03

Version: A/0

Contents

| | |
|--|----|
| 1. Description..... | 2 |
| 2. Safety manual..... | 2 |
| 3. Features..... | 2 |
| 4. Other instructions..... | 2 |
| 5. Precautions before use..... | 3 |
| 6. Product structure..... | 3 |
| 7. Description of LCD display..... | 3 |
| 8. Scope and contraindications of the product..... | 4 |
| 9. Technical indicators..... | 4 |
| 10. Instructions for use..... | 5 |
| 11. Reference temperature..... | 7 |
| 12. Advice | 8 |
| 13. Maintenance and overhaul | 8 |
| 14. Instructions for waste disposal..... | 9 |
| 15. Electromagnetic compatibility warning..... | 9 |
| 16. Symbol description..... | 14 |
| 17. Product maintenance warranty card..... | 15 |
| 18. List of product accessories..... | 17 |
| 19. Statement | 17 |
| 20. Guidance on residual risks..... | 17 |

1. Description

This product is an infrared forehead thermometer that professionally measures the temperature of the human forehead. According to the difference of human skin, the measured temperature will be different; measured temperatures of different parts of the human body are different, because the more exposed the human body parts are to the environment, the more greatly their temperatures will be affected by the ambient temperature.

2. Safety manual

Please read this manual carefully before use and users should use this product according to the manual.

The ambient temperature for the use of this product is 15°C~40°C(59°F~104°F) and the best temperature is 25°C(77°F).

Please do not place this product in an environment with a temperature higher than 50°C (122°F) or lower than 0°C (32°F).

Please do not put this product near live objects to avoid electric shock.

Please do not use this product in an environment with a relative humidity greater than 95%.

Please do not place this product too close to the electromagnetic range. (Such as radio, mobile phone, etc.).

Please do not hit or drop this product. If it is damaged, please do not use it.

Sweat, hair, hats or scarves on the forehead will affect the accuracy of the measurement.

Make sure that the measurement distance is within 3-5 cm.

When the temperature of the forehead cannot reflect the body temperature normally because of sweating on the forehead or other reasons, please measure from the earlobe.

When cleaning is required, please gently wipe the surface of the instrument with alcohol.

Warning: Do not repair or maintain when using the mobile device.

Warning: Do not modify the device without authorization from the manufacturer.

Warning: Do not expose the product to sunlight or near the stove, and do not touch water.

Warning: The device should be out of reach of children and pets to avoid inhalation or swallowing of small parts.

Warning: The device shall be carefully cleaned and disinfected before used for different patients.

3. Features

- 1) Measuring body temperature with high accuracy
- 2) Two temperature units: °C and °F
- 3) Beep alert
- 4) LCD display with backlight
- 5) Automatic range selection; resolution is 0.1°C (0.1°F)
- 6) The latest 20 measurement data can be memorized and stored (press the up and down buttons to check the latest 20 measurement data stored)
- 7) Automatic data saving and automatic shutdown

4. Other instructions

- 1) Non-contact measurement: it is not in direct contact with the human body but only uses the infrared detector to sense the infrared radiation radiated by the human body. Therefore, it will not interfere with the human body or cause any damage to the human body, being suitable for temperature measurement of children.
- 2) Wide measurement range: because the infrared forehead thermometer measures temperature in a non-contact way, it can work at a normal temperature or under the conditions allowed by the thermometer and the measurement range is relatively wide.
- 3) Fast temperature measurement: it can give a quick response. The sensitive element in the infrared detector is very sensitive, as long as the target infrared radiation is received, the temperature can be set quickly in a short time.
- 4) High accuracy: unlike ordinary temperature measurement, the infrared thermometer will not destroy the temperature distribution of the object, so the measurement is relatively accurate.
- 5) High sensitivity: as long as there is a slight change in the temperature of the human body, the radiation energy will change greatly, which is convenient for measurement. And the device is safe

- to use and has a long service life.
- 6) Small size and convenient to carry.
- 7) Less disturbed by the external environment temperature: most infrared detectors are equipped with compensation circuits to compensate for the fluctuation of the external environment temperature.

5. Precautions before use

1) When using the infrared forehead thermometer for the first time, please perform the necessary inspections according to the following steps:

Step 1: Use a traditional thermometer to measure someone, assuming the temperature being 37.5°C (99.5°F).

Step 2: Use the infrared forehead thermometer to measure the same person. When measuring, keep a distance of 3-5 cm between the thermometer and the forehead (note that any obstacles that may affect the measurement, such as hair, sweat, etc. shall be removed.). If you get the same temperature 37.5°C (99.5°F), it means that the infrared forehead thermometer is set up properly and can be used. If you get a low reading, such as 36.4 °C (97.5 °F, a difference of 1.1 °C (2.0 °F)), you need to correct the infrared forehead thermometer by adding the difference. Calibration procedures: **"Note! Operation by non-professionals is not allowed!"** (Remove the battery. After 5S, press and hold + button and function button to power on. After hearing 2 beeps, press -button to enter the calibration mode and get the temperature of the 35-degree standard body and the 40-degree standard body in order. After completing the calibration, change to the object temperature mode to verify the temperature.

Step 3: Measure the temperature of the same person again and check.

2) Self-test after booting

△ Aim towards the target to be measured and press the measurement switch, then the LCD will display all numbers and characters of the self-test with a self-test interface as shown in Figure 1. This interface will exist for about 1 second.



Figure 1:

△ After the self-test is completed, you will hear a beep, indicating that the power-on self-test has been completed, and the temperature of the measured target will be displayed on the LCD.

6. Product structure

The product is mainly composed of infrared sensor head, processor, liquid crystal display (LCD) display, buttons, plastic casing, battery and circuit board.

- ① . Measure button
- ② . LCD display
- ③ . Infrared sensor head
- ④ . Handle
- ⑤ . Up button
- ⑥ . Down button
- ⑦ . Set button
- ⑧ . Battery cover

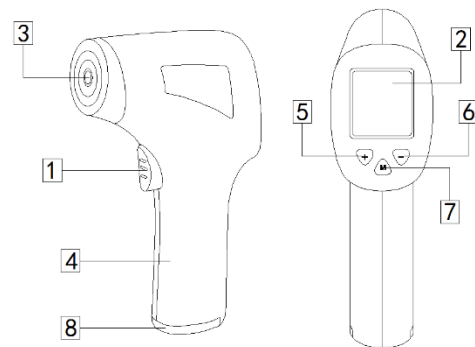

Figure 2:

7. Description of LCD display

- ① .Body temperature mode
- ② .Temperature unit °C or °F
- ③ . Reading
- ④ . Memory
- ⑤ . Data storage times/setting mode standard
- ⑥ . Battery status
- ⑦ . Beep
- ⑧ . Surface mode

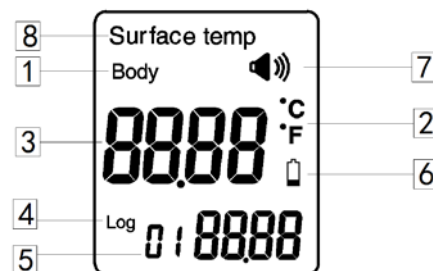

Figure 3:

8. Scope of application and contraindications of the product

8.1 Scope of application of the product

The body temperature of the object is measured by measuring the thermal radiation of the forehead.

8.2 Contraindications of the product

- 1) Birth defects, congenital malformations, septic shock, circulatory failure and other conditions that may seriously affect frontal temperature measurement;
- 2) Suffering from mental disorder;
- 3) Suffering from severe heart, liver, kidney and other diseases;
- 4) Newborns within the first 100 days, children under three years old with defective immune system and severe fever.

9. Technical indicators

9.1 Measurement scope

| | |
|--|---|
| Measurement range of body temperature mode | Body 32.0°C ~43.0°C (89.6°F ~109.4°F) Surface 0.0°C ~100.0°C (32°F ~212°F) |
| Effective measuring distance range | 3~5cm (1.18~1.97 inch) The best measurement distance is 3 cm |
| Automatic shutdown | 13s |

9.2 Measurement accuracy: (32°C ~43°C (89.6°F ~109.4°F)) ±0.2°C (0.4°F)

9.3 Basic parameters

| | |
|---|--|
| Decimal places displayed | 0.1°C (0.1°F) |
| Storage temperature | -20°C ~55°C (-4°F ~13.1°F) |
| Operating ambient temperature | 15°C ~40°C (59°F ~104°F) The best temperature is 25°C (77°F) |
| Relative humidity | ≤95%RH |
| Power supply | DC 3V (2 AAA batteries) |
| Dimensions | 154*87.7*44MM |
| Weight | Net weight 105g (excluding battery weight) |
| Electric shock proof type | Internal power supply |
| Degree of protection against electric shock | Type BF applied part |
| Degree of protection against liquid | Not applicable |
| Operating mode | Continue to operate |
| Production Date | See product nameplate for details |
| Maximum allowable error | ·32.0°C ~43.0°C (89.6°F ~109.4°F) ±0.2°C (0.4°F) within the range is allowed ·32.0°C ~43.0°C (89.6°F ~109.4°F) ±0.3°C (0.5°F) beyond the range is allowed |
| Clinical accuracy | 1) Clinical deviation: ≤ ±0.3°C 2) Clinical standard deviation: ≤ ±0.2°C |
| Measurement position | Forehead |

9.4 Service life

The product life is 2 years (excluding the battery)

9.5 Software release version number: A006

9.6 Environmental requirements for work, storage and transportation

1) Working environment:

■ Ambient temperature: 15°C~40°C (59°F~104°F) with the best temperature being 25°C(77°F);

■ Relative humidity: ≤95%RH

■ Atmospheric pressure: 70Kpa~106Kpa

■ Power supply: DC3V (two AAA batteries)

2) Storage and transportation environment:

■ Ambient temperature: -20°C-55°C (-4°F~13.1°F);

■ Relative humidity: <95%RH;

■ No corrosive gas and the room shall be well ventilated.

■ Transport requirements shall be in accordance with the order contract, but the product must be protected from severe shock, vibration, rain and snow during transportation.

3) Outer packaging environment

■ Ambient temperature: -20°C-55°C(-4°F~13.1°F)

■ Relative humidity: <95%RH;

■ No corrosive gas and the room shall be well ventilated.

■ Transport requirements shall be in accordance with the order contract, but the product must be protected from severe shock, vibration, rain and snow during transportation.

10. Instructions for use

10.1 Instructions for the use of batteries and buttons

1. Instructions for the use of batteries (refer to Figure 4):

There is a removable battery cover at the bottom of the handle, please push it to the direction of the sign by hand.

Figure 4:

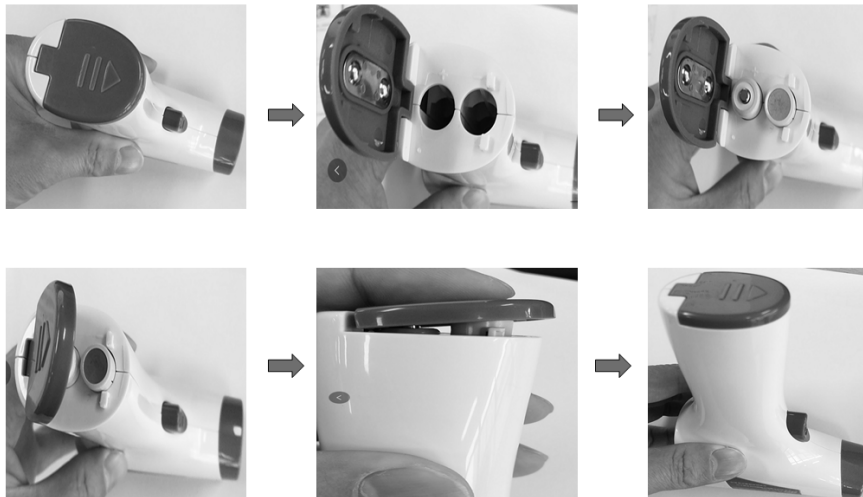

■ Battery installation and replacement matters:

1) After opening the battery cover, insert the battery properly. Make sure the plus sign on the battery matches the plus sign on the device.

2) When the battery power is low, the symbol  will appear on the display, warning to replace the battery. (See Figure 4) Open the battery compartment cover (see product structure ⑧) to replace the battery. When replacing, make sure the plus sign on the battery matches the plus sign on the

device, otherwise it could cause the device or the battery itself to malfunction.

3) When the device has not been used for a long time, please remove the battery to prolong the service life and prevent damage to the thermometer due to battery leakage.

4) The estimated service life of the battery of the infrared thermometer: more than 1000 times.

2. Instructions for buttons

1): Calibration mode: remove the battery, 5S later, press and hold the + button and function button to power on. After hearing 2 beeps, press - button to enter the calibration mode and get the temperature of the 35-degree standard body and the 40-degree standard body in order. After completing the calibration, change to the object temperature mode to verify the temperature.

2): Power button: press the switch to turn on the device; press and hold the button for 15 seconds to turn off the device.

3): Turn on the device and enter the screen self-test. After the beep indicating the end of the self-test, the ambient temperature will be displayed.

4): Measure button: after a short press, the collected temperature will be displayed on the display within 1 second, and the current test record will be kept before the next action.

5): Function button

- The first short press is to switch between body temperature mode and surface temperature mode.

- Press and hold for 3 seconds to enter the setting mode:

- a. F1 --- press + and - to switch between F mode and °C mode;

- b. Another short press to F2 --- alarm temperature setting by pressing + and - to adjust the alarm temperature;

- c. Another short press to F3 --- displayed data offset setting by pressing + and - to adjust the offset value to be displayed;

- d. Another short press to F4 --- buzzer ON/OFF setting by pressing + and - to adjust the sound;

- In the power-on state, press the +/- button to enter the temperature measurement record viewing mode; press + to scroll up and - to scroll down; the latest 20 measurement data can be stored.

3. Data storage

The thermometer can automatically store the latest 20 body temperature values which can be viewed through "+" or "-" button in the power-on state.

10.2 Steps to measure temperature

1. Aim the infrared forehead thermometer at the center of the forehead (above the eyebrows and no hair covering)

Keep the thermometer vertical at a distance of 3 to 5 cm

Press the measure button and the temperature will be displayed immediately.

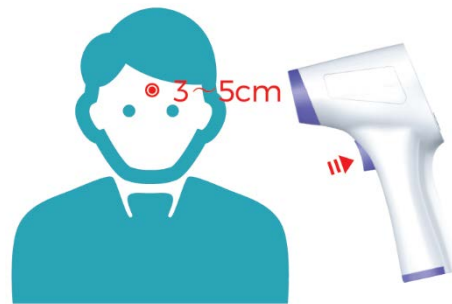

Figure 5:

2. When the measure button (see product structure ①) is pressed, the current temperature value will be displayed, and the measurement data can be automatically stored (press the "+, -" setting button to check the latest 20 measurement data stored)

Note:

1) Before measuring, please make sure that there is no hair, sweat, cosmetics or hats which may cover the forehead.

2) When the forehead temperature cannot reflect the body temperature normally due to sweating or

other reasons, please measure the measure behind the earlobe and meanwhile make sure that there is no hair, sweat, cosmetics or hats.

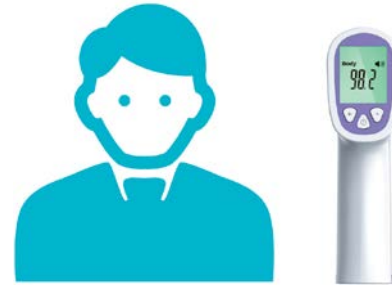

Figure 6:

3) If the infrared thermometer has not been used for a long time, it will check the ambient temperature after booting, and the boot time will be extended by 1 to 2 seconds.

4) Human body temperature changes throughout the day, and is also affected by other external conditions, such as age, gender, skin color, etc.

5) When measuring, it is recommended to measure about three times each time, subject to the most displayed set of data.

11. Reference temperature

11.1 Normal body temperature range for different measurement sites

The human body is a very complex biological integrated system. Body temperature is an important data for whether human life activities are normal. Usually, we check our physical condition by measuring the temperature of the forehead, cochlea, anus, oral cavity and armpits. The body temperature measured on different sites will be different. Refer to the following table for the specific differences:

| Measurement site | Normal temperature (°C) | Normal Fahrenheit (°F) |
|------------------|-------------------------|------------------------|
| Anus | 36.6~38 | 97.8~100.4 |
| Oral cavity | 35.5~37.5 | 95.9~99.5 |
| Armpit | 34.7~37.3 | 94.4~99.1 |
| Ear | 35.8~38 | 96.4~100.4 |

11.2 Normal body temperature range for different ages

Human body temperature changes throughout the day, and is also affected by other external conditions, such as age, gender, skin color, thickness, etc. For the normal body temperature range of different ages, please refer to the table below:

| Age | Normal temperature (°C) | Normal Fahrenheit (°F) |
|-------|-------------------------|------------------------|
| 0~2 | 36.4~38.0 | 97.5~100.4 |
| 3~10 | 36.1~37.8 | 97.0~100.0 |
| 11~65 | 35.9~37.6 | 96.6~99.7 |
| >65 | 35.8~37.5 | 96.4~99.5 |

Note:

- The forehead measured by the infrared forehead thermometer is an exposed part, which is greatly affected by the environment, and will have a deviation of 0.5°C to 1°C. The normal range is 35.5°C to 37.3°C (95.9°F to 99.14°F).

- The body temperature of females is different from that of males. Males' temperature is generally

about 0.3°C higher than that of females. The body temperature during ovulation will increase by 0.3°C~0.5°C than usual.

12. Advice

·The protective sheet outside the LCD frame is very important, and it is also a fragile part of the meter, please be careful when using.

- Please do not charge non-rechargeable batteries nor throw them into fire.
- Please do not expose this product to the sun or touch the water.

13. Maintenance and overhaul

13.1 Product maintenance and cleaning

- 1) The sensor head is the most precise part of the product and must be carefully protected.
- 2) Do not use corrosive cleaning agents to clean this product.
- 3) Do not immerse this product into water or other liquids.
- 4) Keep this product in a dry place to avoid dust, pollution and direct sunlight.
- 5) Please clean the infrared forehead thermometer once a month. If necessary, you can clean it properly according to the actual dirt of the product; please use a dry soft cloth to clean the infrared forehead thermometer. If the device is particularly dirty, wipe its body with alcohol and then dry with a dry cloth.
- 6) Maintenance can be performed by the user or the patient.

13.2 Product overhaul

If you encounter the following problems during use, please follow the maintenance instructions to find a solution. If the problem persists, please contact our customer service.

- 1) The LCD cannot display temperature values

In the temperature measurement mode, when the temperature is lower than 33°C or higher than 43°C, the LCD will not display the data but display “Lo” or “HI”.

- 2) LCD displays "HI"

When using the infrared forehead thermometer, if the LCD displays "HI", it means that the temperature has exceeded the measurement range or the measurement temperature is higher than 43°C in the body temperature measurement mode.

- 4) LCD displays "Lo"

When using the infrared forehead thermometer, if the LCD displays "Lo", it means that the temperature is lower than the measurement range or the measurement temperature is lower than 33°C in the body temperature measurement mode.

When the device displays "Lo" or "HI", you can refer to the following situations:

| | |
|---|--|
| The reason for displaying "Lo" or "HI" | Measured temperature exceeds the measurement range |
| The temperature is affected by hair or sweat | Ensure that there is no obstruction during temperature measurement |
| Temperature is affected by changes in airflow | Ensure that the air remains stable during temperature measurement |

| | |
|---|--|
| Measuring distance is too far | Please note that the measuring distance should not be greater than 5 cm |
| Walk into the room from outdoors of low temperature or high temperature | Please wait for 15 minutes until the body temperature of the person to be measured adapts to the measurement environment |

14. Instructions for waste disposal

■ Electronic products and batteries directly placed in the trash can cause harm to the environment. Please dispose of them according to local regulations.

■ Do not discard the end-of-life infrared thermometer to the trash can and please dispose according to local regulations or contact the manufacturer for recycling.

15. Electromagnetic compatibility warning

Note:

- Comply with the relevant requirements of electromagnetic compatibility of YY0505-2012.
- The user shall install and use according to the electromagnetic compatibility information provided in the random file.
- Portable and mobile RF communication equipment may affect the performance of the infrared forehead thermometer, so avoid strong electromagnetic interference when using the device, such as away from mobile phones, induction cookers, etc.
- Refer to the attachment for guidelines and manufacturers' declarations.

Warning:

- The equipment or system should not be used close to or stacked with other equipment. If it must be used close to or stacked with other equipment, make sure the device can operate normally.

Appendix:

| Guidelines and Manufacturer's Statement-Electromagnetic Emissions | | |
|---|-------------------|---|
| The infrared forehead thermometer is expected to be used in the electromagnetic environment specified below, and the purchaser or user of the device should ensure that it is used in such electromagnetic environment: | | |
| Emission test | Compliance | Electromagnetic environment-guidelines |

| GB4824 RF emission | Group 1 | The infrared forehead thermometer uses RF energy only for its internal functions. Therefore, its RF emissions are very low, and may not cause any interference to nearby electronic equipment. | |
|---|--|--|--|
| GB4824 RF emission | Type B | Infrared thermometers are suitable to be used in all facilities, including household and residential public low-voltage power supply networks directly connected to homes. | |
| GB17625.1 Harmonic emission | Not applicable | | |
| GB17625.12 Voltage fluctuation/flicker emission | Not applicable | | |
| Guidelines and Manufacturer's Statement-Electromagnetic Anti-interference | | | |
| The infrared forehead thermometer is expected to be used in the electromagnetic environment specified below, and the purchaser or user of the infrared thermometer should ensure that it is used in such electromagnetic environment. | | | |
| Anti-interference test | IEC 60601 test level | Compliance level | Electromagnetic environment-guidelines |
| Electrostatic discharge (ESD) GB/T 17626.2 | ± 6 KV contact discharge ± 8 KV air discharge | ± 6 KV contact discharge ± 8 KV air discharge | The floor should be wood, concrete or ceramic tiles. If the floor is covered with synthetic materials, the relative humidity should be at least 30%. |
| Electrical fast transient burst GB/T 17626.4 | ± 2 KV power cord ± 1 KV input/output line | Not applicable | Not applicable |
| Surge GB/T 17626.5 | ± 1 KV differential mode voltage ± 2 KV common mode voltage | Not applicable | Not applicable |

| | | | |
|---|--|--------------------|---|
| Voltage dips, short interruptions and voltage changes on the power input line GB/T 17626.11 | <5%UT for 0.5 weeks (on UT, >95% dip) 40%UT for 5 weeks (60% dip on UT) 70% UT for 25 weeks (30% dip on UT) <5%UT for 5S (>95% 60% dip on UT) | Not applicable | Not applicable |
| Power frequency magnetic field (50/60Hz) GB/T17626.8 | 3A/m | 3A/m/50Hz /60Hz | The power frequency magnetic field should have the characteristics of power frequency magnetic field level in typical places like a typical commercial or hospital environment. |
| Note: UT refers to the AC grid voltage before applying the experimental voltage | | | |
| Guidelines and Manufacturer's Statement-- Electromagnetic Immunity | | | |
| The infrared forehead thermometer is expected to be used in the electromagnetic environment specified below, and the purchaser or user of the infrared thermometer should ensure that it is used in such electromagnetic environment: | | | |
| Anti-interference test | IEC 60601 test level | Compliance level | Electromagnetic environment-guidelines |

Note 1: At 80MHz and 800MH, the higher frequency band formula shall be used.

Note 2: These guidelines may not be suitable for all situations. Electromagnetic propagation is affected by

| | | | |
|---|---|-----------------------------------|---|
| <p>RF conduction GB/T 17625.6</p> <p>RF radiation GB/T 1,7626.3</p> | <p>3 Vrms 150 KHz to 80 MHz</p> <p>3V/m 80 MHz to 2,5 GHz</p> | <p>Not applicable</p> <p>3V/m</p> | <p>Portable and mobile RF communication equipment should not be used closer to any part (including cables) of the infrared thermometer than the recommended isolation distance. The distance should be calculated through the formula corresponding to the transmitter frequency.</p> <p>Recommended isolation distance</p> <p>$d = 1.2 \sqrt{p}$</p> <p>$d = 1.2 \sqrt{p}$ 80 MHz to 800 MHz</p> <p>$d = 2.3 \sqrt{p}$ 800 MHz to 2,5 GHz</p> <p>Where p is the maximum output power rating of the transmitter provided by the transmitter manufacturer, in watts (W), and d is the recommended isolation distance, in meters (m).</p> <p>The field strength of the fixed RF transmitter is determined by surveying the electromagnetic field, and it should be lower than the compliance level in each frequency range.</p> |
|---|---|-----------------------------------|---|

absorption and reflection from buildings, objects and people.

a. The field strength of fixed transmitters, such as: base stations for wireless (cellular/cordless) phones and ground-mounted mobile radios, amateur radio, AM (amplitude modulation) and FM (frequency modulation) radio broadcasts, and television broadcasts, cannot be accurately predicted theoretically. To assess the electromagnetic environment of fixed RF transmitters, surveys of electromagnetic sites should be considered. If the measured field strength of the infrared forehead thermometer is higher than the RF compliance level mentioned above, the infrared forehead thermometer should be observed to verify its normal operation. If abnormal performance is observed, additional measures may be necessary, such as reorienting or relocating the infrared thermometer.

b. In the entire frequency range of 150KHz-80MHz, the field strength should be less than 3V/m.

Recommended isolation distance between portable and mobile RF communication devices and infrared forehead thermometers

The infrared forehead thermometer is expected to be used in an electromagnetic environment where radiated RF disturbances are controlled. According to the maximum output power of the communication equipment, the purchaser or user of the infrared forehead thermometer can prevent electromagnetic interference by maintaining the minimum distance between the portable and mobile RF communication device (transmitter) and the infrared forehead thermometer as recommended below.













| Rated maximum output power of transmitter/w | Isolation distance corresponding to different frequencies of transmitter/m | | |
|---|--|---------------------------------|---------------------------------|
| | 150kHz—80MHz $d=1.2\sqrt{P}$ | 150kHz—80MHz $d=1.2\sqrt{P}$ | 150kHz—80MHz $d=2.3\sqrt{P}$ |
| 0.01 | Not applicable | 0.12 | 0.23 |
| 0.1 | Not applicable | 0.38 | 0.73 |
| 1 | Not applicable | 1.2 | 2.3 |
| 10 | Not applicable | 3.8 | 7.3 |
| 100 | Not applicable | 12 | 2.3 |

For the rated maximum output power of the transmitter not listed in the above table, the recommended isolation distance d, in meters (m), can be determined by the formula in the corresponding transmitter frequency column, Where p is the maximum output power of the transmitter provided by the transmitter manufacturer, in watts (w).

Note 1: At 80MHz and 800MHz frequencies, the formula for the higher frequency range is used.

Note 2: These guidelines may not be suitable for all situations. Electromagnetic propagation is affected by absorption and reflection from buildings, objects and human bodies.

16 Symbol description

| Symbol graphics | Meaning | Symbol graphics | Meaning |
|---|-----------------------------------|--|---|
|  | Note, refer to attached documents |  | Reference instructions |
|  | FCC |  | Certificate of Medical Device in European Union |
|  | FDA |  | BF |
|  | Environmental symbol |  | Recycling logo |
|  | Not rain proof |  | No direct sunlight |
|  | Disposal instructions |  | Trash can |
|  | Temperature limit | | |

17 Product maintenance warranty card

| |
|--|
| <p align="center">Product Maintenance Card (This form is reserved for the seller with this card as a voucher) (This card is for a return visit from the customer service, please be sure to complete it)</p> <p>Customer name: Tel: Address: Product name: Product type: Tracing code: Purchase date: Purchase city:</p> |
| <p>Fault description:</p> |
| <p>Dear customers, be sure to use AAA batteries when replacing batteries</p> |



| |
|--|
| <p align="center">Product Maintenance Card (This form is reserved for the seller with this card as a voucher) (This card is for a return visit from the customer service, please be sure to complete it)</p> <p>Customer name: Tel: Address: Product name: Product type: Tracing code: Purchase date: Purchase city:</p> |
| <p>Fault description:</p> |
| <p>Dear customers, be sure to use AAA batteries when replacing batteries</p> |

Free Warranty Regulations

- (i) Warranty period of this product is from the date of purchase. With a shopping invoice or warranty card, you can enjoy a one-year free warranty and lifetime maintenance service.
- (ii) After use according to the instruction manual and precautions, the fault occurred during the warranty period will be repaired free of charge.
- (iii) Any failures caused by manufacturing problems during the warranty period will be accepted by the service centers or repair stations of the company.
- (iv) During the warranty period, free repair would not be available in the following conditions:
 - (1) Unauthorized disassembly and modification of the product.
 - (2) Improper storage, such as failure and damage caused by transportation damage, bumps, battery leakage, etc.
 - (3) Damage caused by force majeure (fire, earthquake, flood, lightning strike, etc.).
 - (4) Failure caused by not following the correct instructions in the instruction manual.
 - (5) The warranty is invalid if the product maintenance card or invoice is altered without authorization.
- (v) When requesting free warranty service, you must hold the warranty card filled with the date of purchase and the shop seal (including shop name and address). Please ask the shop assistant to stamp the warranty card when purchasing this product.
- (vi) Repair services beyond the scope of warranty will be charged according to regulations.



Free Warranty Regulations

- (i) Warranty period of this product is from the date of purchase. With a shopping invoice or warranty card, you can enjoy a one-year free warranty and lifetime maintenance service.
- (ii) After use according to the instruction manual and precautions, the fault occurred during the warranty period will be repaired free of charge.
- (iii) Any failures caused by manufacturing problems during the warranty period will be accepted by the service centers or repair stations of the company.
- (iv) During the warranty period, free repair would not be available in the following conditions:
 - (1) Unauthorized disassembly and modification of the product.
 - (2) Improper storage, such as failure and damage caused by transportation damage, bumps, battery leakage, etc.
 - (3) Damage caused by force majeure (fire, earthquake, flood, lightning strike, etc.).
 - (4) Failure caused by not following the correct instructions in the instruction manual.
 - (5) The warranty is invalid if the product maintenance card or invoice is altered without authorization.
- (v) When requesting free warranty service, you must hold the warranty card filled with the date of purchase and the shop seal (including shop name and address). Please ask the shop assistant to stamp the warranty card when purchasing this product.
- (vi) Repair services beyond the scope of warranty will be charged according to regulations.

18. List of product accessories

One QY-EWQ-01 infrared forehead thermometer, one manual, one certificate, and the specific configuration is subject to the actual product.

19. Statement

If necessary, the company can provide the required circuit diagrams, component lists, legends, calibration details, or other materials needed by qualified technical personnel of the user to repair the equipment parts that allowed to be repaired by the manufacturer.

20. Guidance on residual risks

- A comprehensive residual risk assessment should examine the comprehensive impact of a single residual risk from all aspects.

- The work shall be completed by the personnel with professional knowledge, experience and authority. It usually includes application experts with medical knowledge and experience.